



TECHNODRIVE

Riduttore - Gearbox - Réducteur

Modello
Model
Type

RCV

Potenza Max - Max power - Puissance Maxi
150 Kw - 204 HP

Carcassa in ghisa
Cast iron housing
Carter en fonte

Senso di rotazione - Rotation direction - Sens de rotation

- **D**: senso invertito - reverse rotation - sens inverse
- **S**: stesso senso - equal rotation - même sens

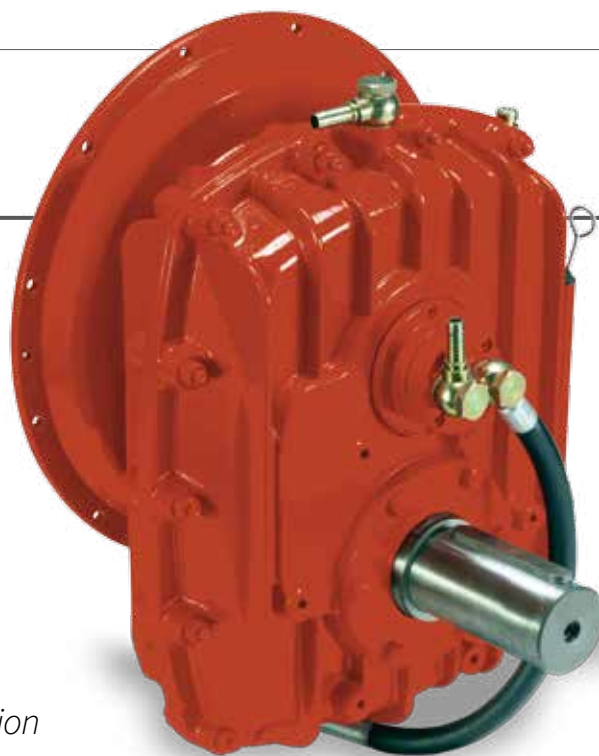

Caratteristiche tecniche - Technical data - Caracteristiques techniques

| Rapporto Ratio Rapport | Coppia Max entrata Max input torque Couple maxi à l'entrée | Velocità Max entrata Max input speed Vitesse maxi à l'entrée | Rapporto Ratio Rapport | Coppia Max entrata Max input torque Couple maxi à l'entrée | Velocità Max entrata Max input speed Vitesse maxi à l'entrée |
|------------------------------|--|--|------------------------------|--|--|
| D | M1 (Nm) | N1 (RPM) | S | M1 (Nm) | N1 (RPM) |
| 0,50 | 1000 | 2000 | 0,67 | 830 | 2000 |
| 1,02 | 880 | 2500 | 1,50 | 500 | 2500 |
| 1,50 | 740 | 2500 | 2,00 | 480 | 2500 |
| 1,70 | 740 | 2500 | | | |
| 2,00 | 700 | 2500 | | | |

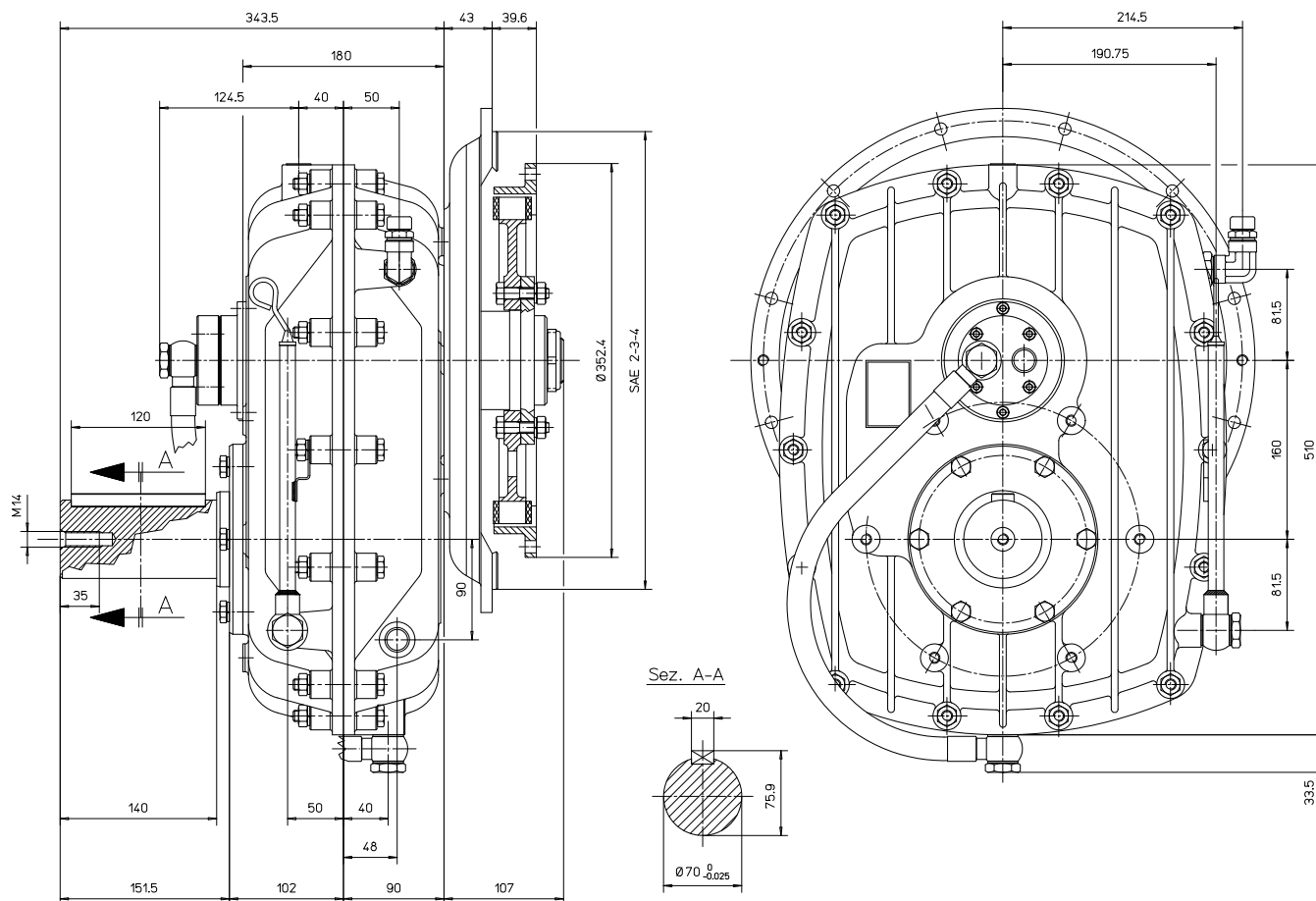

Configurazioni in entrata - *Input configurations - Configurations à l'entrée*

Per accoppiamento a motori Diesel - *To couple Diesel engines - Pour accouplement sur les moteurs Diesel*

Campane SAE - *SAE Housings - Cloches SAE*: SAE 2-3-4

Giunti - *Flexible couplings - Accouplements*: 11,5"

Configurazioni in uscita - *Output configurations - Configurations à la sortie*

Albero Cilindrico - *Cylindrical Shaft - Arbre cylindrique*: $\varnothing 70$ mm

Albero Scanalato - *Spline Shaft - Arbre Cannelé*: ASAE 1"3/8



TECHNODRIVE

TWIN DISC S.r.l.

Via S. Cristoforo, 131 - 40017 S. M. Decima (BO) - ITALIA
 Tel. 0039.051/6819711 - Fax 0039.051/6824234 - 6825814
 info.technodrive@twindisc.com
 www.twindisc.it - www.twindisc.com